



# JOSAM cab bench



## ***The most efficient equipment of its kind for straightening and repairing damaged truck cabs.***

- ✓ The JOSAM cab bench is a strong and stable aligning jig which simplifies cab repair. Moveable mounting points make it easier to mount even severely damaged cabs. The base of the cab is pushed and pulled hydraulically into its correct position.
- ✓ Adapter sets are available for sixty different cab models manufactured by MERCEDES, MAN, IVECO, RENAULT, SCANIA, VOLVO, DAF, FORD and HINO.
- ✓ JOSAM straightening trolleys are equipped with extended high-reach beams, stays and other special accessories and assist in straightening and repairing the cab's vertical frame members and roof section.

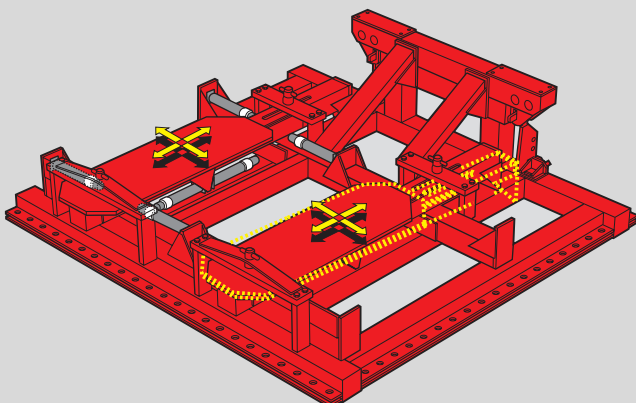

## **JOSAM cab bench**

consists of a rigid base which is anchored to I-beams embedded in the workshop floor or floor anchoring drilled into an existing floor (JOATP151). Even a severely damaged cab can be mounted thanks to the movable jig fixtures. The cab floor structure is then hydraulically straightened with moveable 10 ton cylinders located within the bench.

## JOSAM cab bench



The four mounting points of the damaged cab are anchored to the bench by means of specially designed adapter sets for each cab model. Badly displaced front mounting points are held and pressed into the correct position by using a hydraulic cylinder and moveable jig members. Locating pins are used to guide the mounting points into the correct position.



In addition, the rear part of the cab bench is moveable, which enables vertical straightening of a distorted cab. The cab is pressed upwards to its correct position so that it is in the same vertical line as the cab bench itself.

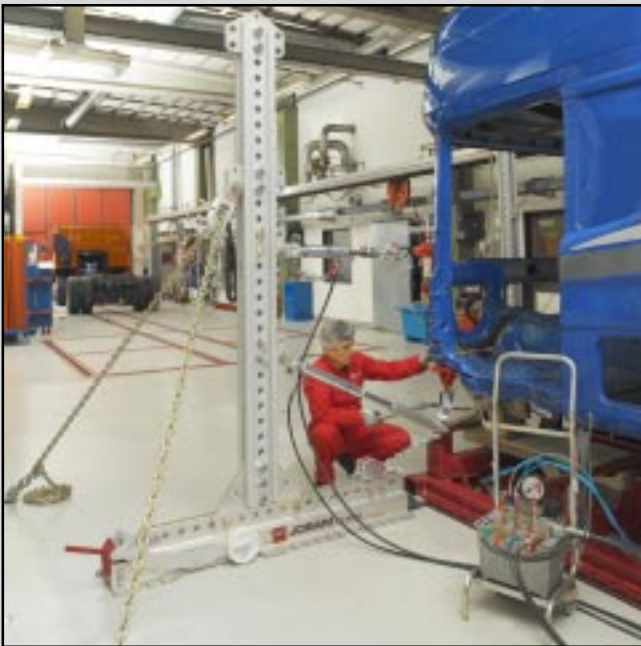

The cab's corner pillar is straightened with press and pull cylinders attached to the tower. This picture shows a vector pull where the lower part of the cab is simultaneously pulled downwards as the A-post is being straightened out.



The JOSAM cab bench works together with our aluminium straightening towers and extra accessories related to pulling and pressing. Our laser measuring systems for cabs, JOSAM cabaligner, is placed directly on the bench and is used for checking measurements.

Representative:

Manufacturer:



# JOSAM

Box 419 • SE-701 48 ÖREBRO • Sweden  
Phone: +46 19 30 40 00 • Fax +46 19 32 03 16  
E-mail: [info@josam.se](mailto:info@josam.se) • Internet: [www.josam.se](http://www.josam.se)